



MODEL: 005792-0

Owner's Manual

iX 1600 Digital Inverter Generator

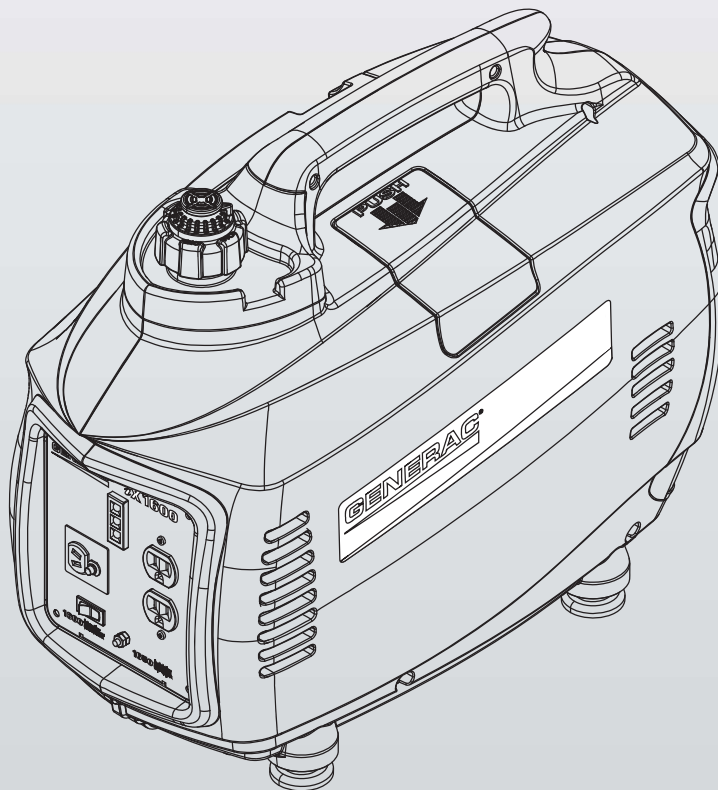

Table of Contents

Accessory Box	Inside Front Cover
Introduction	1
Read this Manual Thoroughly	1
Safety Rules	1
Standards Index	3
Section 1 - General Information	4
Specifications	4
Unit Identification	4
Control Panel.....	4
Section 2 - Operation	5
Pre-Use Check.....	5
Starting the Generator	5
Adding Loads.....	6
Using the FlexPower™ Switch	7
Using the 12 VDC Battery Charger	7
Shutting Down	7
Low Oil Level Shutdown.....	7
Fueling the Generator	8
To Fill the Fuel Tank	8
Adding Engine Oil.....	8
To Add Engine Oil to the Crankcase	8
Section 3 - Maintenance	9
Generator Maintenance	9
Generator Maintenance Schedule	9
Cleaning the Generator	9
Engine Maintenance	9
Changing the Engine Oil	10
Changing the Fuel Filter	10
Changing the Spark Plug	10
Transportation and Storage	11
Section 4 - Troubleshooting	12
Troubleshooting Guide.....	12
Section 5 - Notes	13
Section 6 - Warranty	12

ACCESSORY BOX

Check all contents. If any parts are missing or damaged locate an authorized dealer at 1-888-436-3722.

Contents include:

- 1 bottle SAE 30 Oil
- Spark Plug Wrench
- Battery Charge Cable
- Oil Funnel
- Screwdriver

INTRODUCTION

Thank you for purchasing this model by Generac Power Systems, Inc. This model is a compact, high performance, air-cooled, engine driven generator designed to supply electrical power to operate electrical loads where no utility power is available or in place of utility due to a power outage.

READ THIS MANUAL THOROUGHLY

If any portion of this manual is not understood, contact the nearest Authorized Dealer for starting, operating and servicing procedures.

The operator is responsible for proper and safe use of the equipment. We strongly recommend that the operator read this manual and thoroughly understand all instructions before using the equipment. We also strongly recommend instructing other users to properly start and operate the unit. This prepares them if they need to operate the equipment in an emergency. Save these instructions for future reference. If you loan this unit to someone, ALWAYS loan these instructions to the individual as well.

The generator can operate safely, efficiently and reliably only if it is properly located, operated and maintained. Before operating or servicing the generator:

- Become familiar with and strictly adhere to all local, state and national codes and regulations.
- Study all safety warnings in this manual and on the product carefully.
- Become familiar with this manual and the unit before use.

The manufacturer cannot anticipate every possible circumstance that might involve a hazard. The warnings in this manual, and on tags and decals affixed to the unit are, therefore, not all inclusive. If using a procedure, work method or operating technique that the manufacturer does not specifically recommend, ensure that it is safe for others. Also make sure the procedure, work method or operating technique utilized does not render the generator unsafe.

THE INFORMATION CONTAINED HEREIN WAS BASED ON MACHINES IN PRODUCTION AT THE TIME OF PUBLICATION. GENERAC RESERVES THE RIGHT TO MODIFY THIS MANUAL AT ANY TIME.

SAFETY RULES

Throughout this publication, and on tags and decals affixed to the generator, DANGER, WARNING, CAUTION and NOTE blocks are used to alert personnel to special instructions about a particular operation that may be hazardous if performed incorrectly or carelessly. Observe them carefully. Their definitions are as follows:

DANGER!

INDICATES A HAZARDOUS SITUATION OR ACTION WHICH, IF NOT AVOIDED, WILL RESULT IN DEATH OR SERIOUS INJURY.

WARNING!

Indicates a hazardous situation or action which, if not avoided, could result in death or serious injury.

CAUTION!

Indicates a hazardous situation or action which, if not avoided, could result in minor or moderate injury.

NOTE:

Notes contain additional information important to a procedure and will be found within the regular text body of this manual.

These safety warnings cannot eliminate the hazards that they indicate. Common sense and strict compliance with the special instructions while performing the action or service are essential to preventing accidents.

Four commonly used safety symbols accompany the **DANGER**, **WARNING** and **CAUTION** blocks. The type of information each indicates is as follows:

 **This symbol points out important safety information that, if not followed, could endanger personal safety and/or property of others.**

 **This symbol points out potential explosion hazard.**

 **This symbol points out potential fire hazard.**

 **This symbol points out potential electrical shock hazard.**

GENERAL HAZARDS

- Never operate in an enclosed area or indoors EVEN IF doors and windows are open.
- For safety reasons, the manufacturer recommends that the maintenance of this equipment is carried out by an Authorized Dealer. Inspect the generator regularly, and contact the nearest Authorized Dealer for parts needing repair or replacement.
- Operate generator only on level surfaces and where it will not be exposed to excessive moisture, dirt, dust or corrosive vapors.
- Keep hands, feet, clothing, etc., away from drive belts, fans, and other moving parts. Never remove any fan guard or shield while the unit is operating.
- Certain parts of the generator get extremely hot during operation. Keep clear of the generator until it has cooled to avoid severe burns.
- Do NOT operate generator in the rain.
- Do not alter the construction of the generator or change controls which might create an unsafe operating condition.
- Never start or stop the unit with electrical loads connected to receptacles AND with connected devices turned ON. Start the engine and let it stabilize before connecting electrical loads. Disconnect all electrical loads before shutting down the generator.
- Do not insert objects through unit's cooling slots.
- When working on this equipment, remain alert at all times. Never work on the equipment when physically or mentally fatigued.

Safety Rules

- Never use the generator or any of its parts as a step. Stepping on the unit can stress and break parts, and may result in dangerous operating conditions from leaking exhaust gases, fuel leakage, oil leakage, etc.
- On electric start models, disconnect the POSITIVE (+) battery cable from the engine starter OR the NEGATIVE (-) battery cable from the battery terminal, whichever is easier, before transporting the generator.

EXHAUST & LOCATION HAZARDS

- **NEVER use inside, or in partly enclosed areas such as garages, EVEN IF doors and windows are open! ONLY use outdoors and far from windows, doors and vents. Only use in an area that will not accumulate deadly exhaust.**



- The engine exhaust fumes contain carbon monoxide, which you cannot see or smell. This poisonous gas, if breathed in sufficient concentrations, can cause unconsciousness or even death.
- Adequate, unobstructed flow of cooling and ventilating air is critical to correct generator operation. Do not alter the installation or permit even partial blockage of ventilation provisions, as this can seriously affect safe operation of the generator. The generator **MUST** be operated outdoors.
- This exhaust system must be properly maintained. Do nothing that might render the exhaust system unsafe or in noncompliance with any local codes and/or standards.
- Always use a battery operated carbon monoxide alarm indoors, installed according to the manufacturers instructions.
- If you start to feel sick, dizzy, or weak after the generator has been running, move to fresh air **IMMEDIATELY**. See a doctor, as you could have carbon monoxide poisoning.

ELECTRICAL HAZARDS

- The generator produces dangerously high voltage when in operation. Avoid contact with bare wires, terminals, connections, etc., while the unit is running, even on equipment connected to the generator. Ensure all appropriate covers, guards and barriers are in place before operating the generator.
- Never handle any kind of electrical cord or device while standing in water, while barefoot or while hands or feet are wet. **DANGEROUS ELECTRICAL SHOCK MAY RESULT.**
- The National Electric Code (NEC) requires the frame and external electrically conductive parts of the generator be properly connected to an approved earth ground. Local electrical codes may also require proper grounding of the generator. Consult with a local electrician for grounding requirements in the area.
- Use a ground fault circuit interrupter in any damp or highly conductive area (such as metal decking or steel work).
- Do not use worn, bare, frayed or otherwise damaged electrical cord sets with the generator.
- Before performing any maintenance on the generator, disconnect the engine starting battery (if equipped) to prevent accidental start up. Disconnect the cable from the battery post indicated by a NEGATIVE, NEG or (-) first. Reconnect that cable last.
- In case of accident caused by electric shock, immediately shut down the source of electrical power. If this is not possible, attempt to free the victim from the live conductor. **AVOID DIRECT CONTACT WITH THE VICTIM.** Use a non-conducting implement, such as a rope or board, to free the victim from the live conductor. If the victim is unconscious, apply first aid and get immediate medical help.

FIRE HAZARDS

- **Gasoline is highly FLAMMABLE and its vapors are EXPLOSIVE. Do not permit smoking, open flames, sparks or heat in the vicinity while handling gasoline.**
- Never add fuel while unit is running or hot. Allow engine to cool completely before adding fuel.
- **Never fill fuel tank indoors.** Comply with all laws regulating storage and handling of gasoline.
- **Do not overfill the fuel tank. Always allow room for fuel expansion.** If tank is over-filled, fuel can overflow onto a hot engine and cause FIRE or an EXPLOSION. Never store generator with fuel in tank where gasoline vapors might reach an open flame, spark or pilot light (as on a furnace, water heater or clothes dryer). FIRE or EXPLOSION may result. Allow unit to cool entirely before storage.
- Wipe up any fuel or oil spills immediately. Ensure that no combustible materials are left on or near the generator. Keep the area surrounding the generator clean and free from debris and keep a clearance of five (5) feet on all side to allow for proper ventilation of the generator.

- Do not insert objects through unit's cooling slots.
- **Do not** operate the generator if connected electrical devices overheat, if electrical output is lost, if engine or generator sparks or if flames or smoke are observed while unit is running.
- Keep a fire extinguisher near the generator at all times.

MODEL NO:	
SERIAL NO:	

Figure 1 - Generator ID Plate

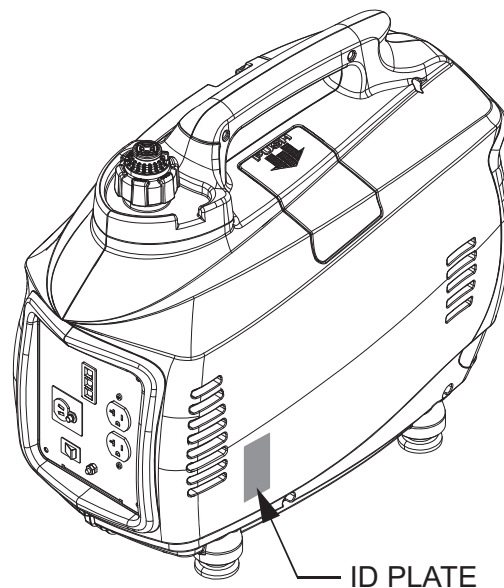

STANDARDS INDEX

In the absence of pertinent standards, codes, regulations and laws, the published information listed below may be used as a guideline for operation of this equipment. Always reference the latest revision available for the standards listed.

1. NFPA No. 70, NFPA HANDBOOK OF NATIONAL ELECTRIC CODE.
2. Article X, NATIONAL BUILDING CODE, available from the American Insurance Association, 85 John Street, New York, N.Y. 10038.
3. AGRICULTURAL WIRING HANDBOOK, available from the Food and Energy Council, 909 University Avenue, Columbia, MO 65201.
4. ASAE EP-3634, INSTALLATION AND MAINTENANCE OF FARM STANDBY ELECTRICAL SYSTEMS, available from the American Society of Agricultural Engineers, 2950 Niles Road, St. Joseph, MI 49085.

CALIFORNIA PROPOSITION 65 WARNING

Engine exhaust and some of its constituents are known to the State of California to cause cancer, birth defects and other reproductive harm.

CALIFORNIA PROPOSITION 65 WARNING

This product contains or emits chemicals known to the State of California to cause cancer, birth defects and other reproductive harm.

General Information

SPECIFICATIONS

Engine Type	Single Cylinder, 4-Stroke
Engine Size	99cc
Starter Type	Recoil
Fuel Capacity/Type	0.8 Gal (3.04L)/Unleaded
Oil Capacity	0.63 Qt (0.6L)
Runtime Full/Half Load	2.5/4.9 Hours
Spark Plug Type	Denso U16FSR-UB or NGK CR5H88
Spark Plug Gap	.030"
Dimensions L x W x H (in)	22 x 12 x 18
Weight Lb/kg	43.5/19.7
Maximum AC Output	1600W
Surge AC Output	1650W
AC Volts	120 VAC
Rated AC Current	13.3 A
Frequency	60 Hz
THD	3.0%
Insulation Class	Class F
Outlets	(2) 5-15R, (1) 12 VDC
DC Volts	12 VDC
Rated DC Current	5 A

NOTE:

Power output and runtime are influenced by many factors, some of which are fuel quality, ambient temperature and engine condition. Output decreases approximately 3.5% for each 1,000 feet above sea level and 1% for every 10 degrees above 60°F.

UNIT IDENTIFICATION (Figure 2)

1. Carrying Handle: Lift the generator by this handle only.
2. Spark Plug Cover: Allows access to the engine spark plug.
3. Fuel System Primer: Used to prime the fuel system for starting.
4. Fuel Cap Pressure Valve: Allows air to enter the fuel tank to equalize pressure.
5. Fuel Tank Cap: Access to fuel tank for filling.
6. Control Panel: location of generator controls and output receptacles.
7. Air Intake Slats: Allows for cooling air to enter the housing.
8. Muffler: Lowers engine exhaust noise.
9. Choke: Cold engine starting aid
10. Left Side Service Cover: Allows access to air filter, fuel filter and oil fill.
11. Vent Hoses: Hoses allow venting of the carburetor.
12. Fuel Shutoff: Controls fuel supply to the carburetor.
13. Starter Rope: Pull rope for starting engine.

Figure 2 - Unit Identification

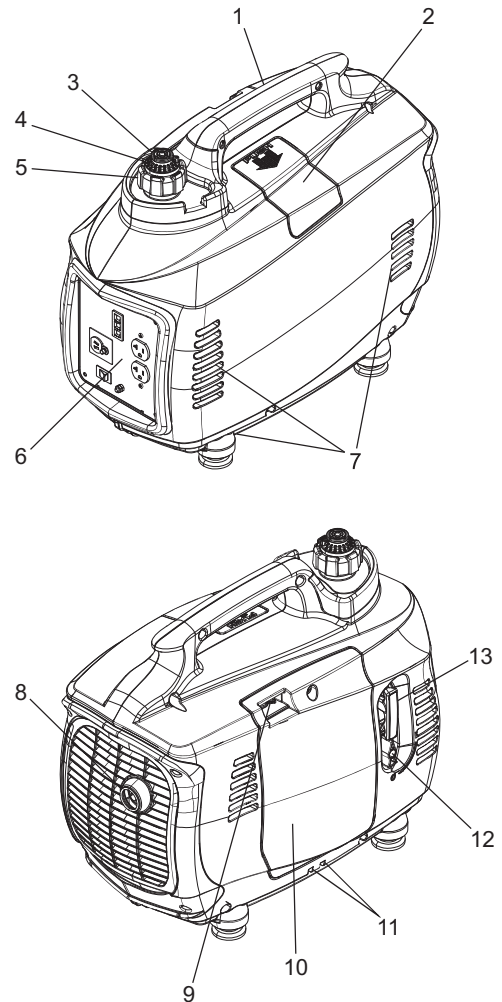

CONTROL PANEL (Figure 3)

14. LOW OIL LEVEL LED (yellow): Lights up when oil level is below safe operating level and the engine shuts down..
15. OVERLOAD LED (red): Lights up if the generator experiences a load greater than the rated output, low voltage, overheats or the powered circuit experiences a short. The output is stopped even though the engine keeps running.
16. READY LED (green): Indicates output from the generator unless there is a low oil or overload condition.
17. 12 VDC Plug: Connection for re-charging 12VDC automotive-style batteries while generator is in operation.
18. FlexPower™ Switch: This switch slows the engine speed when the load is reduced to save fuel and engine wear.
19. 12 VDC Circuit Breaker: Overload protection for the 12 VDC charging system.
20. Ground (Earth) Connection Lug: Grounding point for the generator; consult state and local electrical codes before use (floating ground).
21. 120 VAC Receptacles: Two (2) receptacles for connecting accessories.

NOTE:

Do not exceed the rated output of the generator.

Figure 3 - Control Panel

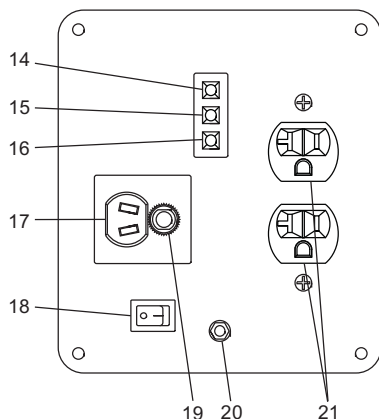

PRE-USE CHECK

Prior to starting the generator and adding loads, perform the following tasks:

1. Make sure the generator is on a firm, level, non-combustible surface with at least five (5) feet of clearance on all sides.

⚠ DANGER!

⚠ Never operate in an enclosed area or indoors! NEVER use in the home, or in partly enclosed areas such as garages, even if doors and windows are open! ONLY use outdoors and far from open windows, doors, vents, and in an area that will not accumulate deadly exhaust.

⚠ DANGER

Using a generator indoors CAN KILL YOU IN MINUTES.
Generator exhaust contains carbon monoxide. This is a poison you cannot see or smell.

<p style="font-size: small; margin: 0;">NEVER use inside a home or garage, EVEN IF doors and windows are open.</p>	<p style="font-size: small; margin: 0;">Only use OUTSIDE and far away from windows, doors, and vents.</p>
--	--

2. Remove the fuel cap and check the fuel level. If fuel is needed, see the section "FUELING THE GENERATOR".
3. Remove the left side service cover and check the oil level by removing the oil filler cap. The oil level should be to the bottom of the threads on the oil fill pipe. If oil is needed, see the section "ADDING ENGINE OIL".

4. Replace and secure the left side service cover.
5. Make sure there are no loads connected to the generator.
6. The National Electric Code (NEC) requires the frame and external electrically conductive parts of the generator be properly connected to an approved earth ground. Proper grounding of the generator will prevent electrical shock in the event of a ground fault condition in the generator or in connected electrical devices. Proper grounding also helps dissipate static electricity, which often builds up in unguarded devices.
7. Local electrical codes may also require proper grounding of the generator.

⚠ CAUTION!

⚠ Starting the generator with accessories connected to the 120 VAC outlets will damage the generator and the connected accessories.

STARTING THE GENERATOR

Once the fuel and oil levels have been checked and it has been verified there are no loads connected, the generator may be started. Turn the FlexPower Switch OFF (O).

1. Open the fuel valve (Figure 4), located below the starter rope pull, by turning to the valve 90° counter-clockwise to the "ON" (I) position.

Figure 4 - Fuel Valve

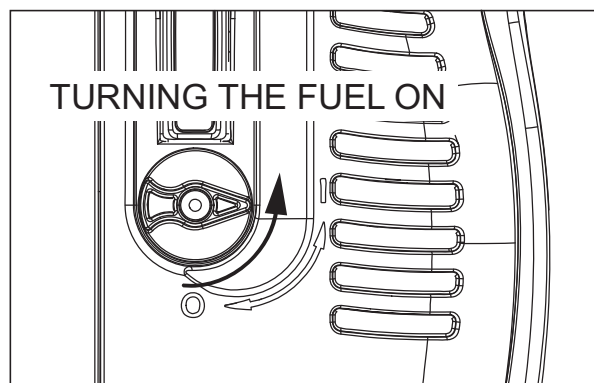

2. Pull up on the center of the fuel fill cap and prime the fuel system by depressing the plunger up to five (5) times with the vent closed (Figure 5 on next page).
3. Open the fuel vent on the top of the fuel fill cap by turning the center portion to the "ON" mark (Figure 6 on next page).
4. If the engine is cold or has not been run for some time, engage the choke by pushing the choke lever to the right.
5. Grip the handle for the pull starter and brace your other hand against the generator. Pull the rope slowly until resistance is felt, then pull the rope rapidly.
6. If the engine does not start, repeat steps 2-5 until the engine fires and begins to run.

Operation

- Carefully adjust the choke to approximately the 1/2 position until the engine begins to run smoothly, then push the lever all the way to the left (Figure 6).
- Make sure the bottom of the generator is not blocked by sand, leaves, grass, etc. as the cooling vents are located on the bottom of the unit.

Figure 5 - Prime Fuel System

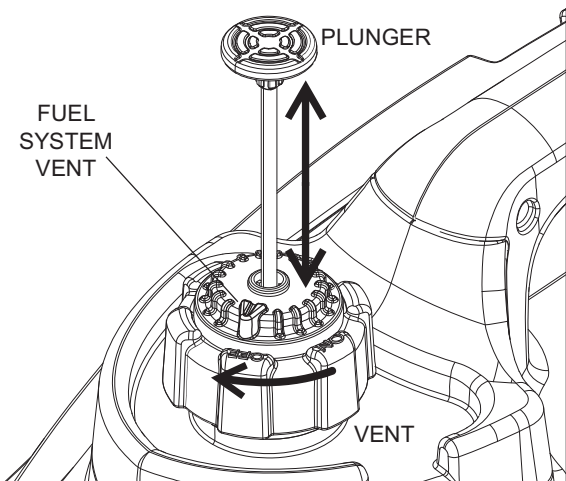
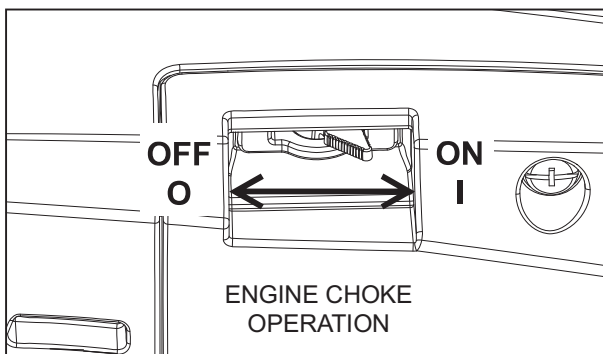

Figure 6 - Adjust Choke



- DO NOT overload the generator; if the red "overload" LED lights up and the accessories attached to the generator stop operating, stop the engine and reduce the load to the generator. Restart and apply reduced loads.
- Consult the following table to estimate what can be powered by the generator.

Device	Running Watts
*Air Conditioner (12,000 Btu)	1700
*Air Conditioner (24,000 Btu)	3800
*Air Conditioner (40,000 Btu)	6000
Battery Charger (20 Amp)	500
Belt Sander (3")	1000
Chain Saw	1200
Circular Saw (6-1/2")	800 to 1000
*Clothes Dryer (Electric)	5750
*Clothes Dryer (Gas)	700
*Clothes Washer	1150
Coffee Maker	1750
*Compressor (1 HP)	2000
*Compressor (3/4 HP)	1800
*Compressor (1/2 HP)	1400
Curling Iron	700
*Dehumidifier	650
Disc Sander (9")	1200
Edge Trimmer	500
Electric Blanket	400
Electric Nail Gun	1200
Electric Range (per element)	1500
Electric Skillet	1250
*Freezer	700
*Furnace Fan (3/5 HP)	875
*Garage Door Opener	500 to 750
Hair Dryer	1200
Hand Drill	250 to 1100
Hedge Trimmer	450
Impact Wrench	500
Iron	1200
*Jet Pump	800
Lawn Mower	1200
Light Bulb	100
Microwave Oven	700 to 1000
*Milk Cooler	1100
Oil Burner on Furnace	300
Oil Fired Space Heater (140,000 Btu)	400
Oil Fired Space Heater (85,000 Btu)	225
Oil Fired Space Heater (30,000 Btu)	150
*Paint Sprayer, Airless (1/3 HP)	600
Paint Sprayer, Airless (handheld)	150
Radio	50 to 200
*Refrigerator	700
Slow Cooker	200
*Submersible Pump (1-1/2 HP)	2800
*Submersible Pump (1 HP)	2000
*Submersible Pump (1/2 HP)	1500
*Sump Pump	800 to 1050
* Allow three (3) times the listed running watts for starting these devices.	

ADDING LOADS

Once the generator has been running smoothly for 2-3 minutes, electrical loads can be added.

⚠ WARNING!

⚠ Do not use worn, bare, frayed or otherwise damaged electrical cord sets with the generator. Do not handle any kind of electrical device while standing in water, while barefoot, or while hands or feet are wet.

- There are two grounded 120 VAC duplex outlets on the front of the generator.

NOTE:

When an electric motor is started, the "OVERLOAD" LED may light up for up to five (5) seconds (this is normal). If it stays on, a fault has occurred. Remove all loads and shut down generator to reset the alarm. Restart the generator. If the "OVERLOAD" LED remains lit, contact a Generac Dealer for assistance.

USING THE FLEXPPOWER™ SWITCH

When the accessories connected to the generator are going to be used intermittently (such as a hand drill), the FlexPower™ switch can be pushed to the "ON" (I) position. This will lower the generator engine speed when loads are not being applied, saving fuel, reducing engine wear and extending runtime.

USING THE 12 VDC BATTERY CHARGER

The 12 VDC receptacle may be used to recharge 12 VDC automotive batteries only. The DC charging output is not regulated. The circuit protector does not prevent over-charging a battery.

1. Connect the charging cable to the generator first, then the battery, ALWAYS connecting the red lead to positive (+) and the black to negative (-).

⚠ DANGER!

⚠ Do not permit smoking, open flame, sparks or any other source of heat around a battery. Wear protective goggles, rubber apron and rubber gloves when working around a battery. Battery electrolyte fluid is an extremely corrosive sulfuric acid solution that can cause severe burns. If a spill occurs, flush area with clear water immediately.

⚠ Storage batteries give off explosive hydrogen gas while recharging. An explosive mixture will remain around the battery for a long time after it has been charged. The slightest spark can ignite the hydrogen and cause an explosion. Such an explosion can shatter the battery and cause blindness or other serious injury.

⚠ NEVER reverse the polarity when connecting the battery terminals to the charging jack. Severe damage may occur to the generator and battery.

2. Keep the FlexPower™ switch in the "OFF" (O) position.
3. Start the generator and use it as normal. Charging time will vary with battery size and condition. Check the voltage at the battery terminals once the charging cable has been unplugged or the generator has been shut down.

NOTE:

This receptacle can not recharge 6-Volt batteries and can not be used to crank an engine having a discharged battery.

SHUTTING DOWN

Once the generator is no longer needed it can be shut down.

1. Switch off any accessories connected to the generator. Unplug any cords to the 120 VAC duplex outlets or the 12 VDC plug.
2. Turn the fuel valve to the "OFF" (O) position (Figure 7). A switch behind the fuel valve grounds the ignition system, stopping the engine and the fuel supply is shut off.
3. Close the vent on the fuel cap.
4. Allow the generator to cool before moving or storing.

⚠ CAUTION!

⚠ Always allow the generator to cool off before storing. High temperatures will be present at the rear of the unit for some time after shutdown.

Figure 7 - Turn Off Fuel

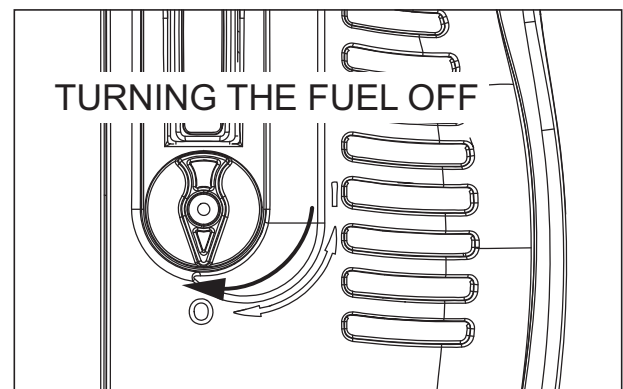

LOW OIL LEVEL SHUTDOWN

This generator is equipped with a low oil level shut down. If the oil level in the engine crankcase drops below a pre-determined level, the engine will stop automatically and the "LOW OIL LEVEL" LED will light up.

Remove the Left Side Service Cover and check the oil level of the engine. Add or drain oil as necessary; refer to see the section "ADDING ENGINE OIL".

Operation

FUELING THE GENERATOR

Use care when fueling the generator. Only fill the fuel tank when the generator has cooled entirely. Use fresh unleaded gasoline with a minimum Research Octane Number (RON) of 87.

NOTE:

Do not use any gasoline containing more than 10% Ethanol. NEVER fill the fuel tank with E85 or a mixture of oil and gasoline designated for two-cycle engines.

⚠ DANGER!

Do not light a cigarette or smoke when filling the fuel tank.

⚠ Gasoline is highly **FLAMMABLE** and its vapors are **EXPLOSIVE**. Do not permit smoking, open flames, sparks or heat in the vicinity while handling gasoline.

⚠ Never fill fuel tank indoors. never fill fuel tank when engine is running or hot. avoid spilling gasoline on a hot engine. allow engine to cool entirely before filling fuel tank.

⚠ Do not overfill the fuel tank. Always allow room for fuel expansion. If tank is over-filled, fuel can overflow onto a hot engine and cause **FIRE** or an **EXPLOSION**. Wipe up fuel spills immediately!

TO FILL THE FUEL TANK

1. Remove the fuel tank cap.

Figure 8 - Fuel Tank Cap

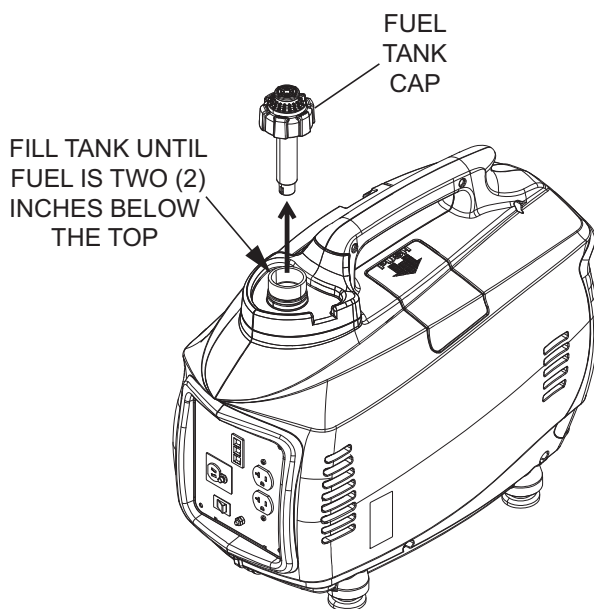

2. Add fuel slowly, stopping about two (2) inches below the top of the filler neck.
3. Replace the fuel tank cap. Make sure the valve on the fuel cap is in the "OFF" position.
4. If the generator is going to be started, refer to the section "STARTING THE GENERATOR" for additional directions on priming the fuel system.

ADDING ENGINE OIL

All oil should meet minimum American Petroleum Institute (API) Service Class SJ, SL or better. Do not use any aftermarket additives.

Select the oil's viscosity grade according to the expected operating temperature, only a little more than one-half quart is needed.

- Above 40° F, use SAE 30
- Below 40° F to 10° F, use 10W-30
- Below 10° F, use synthetic 5W-30

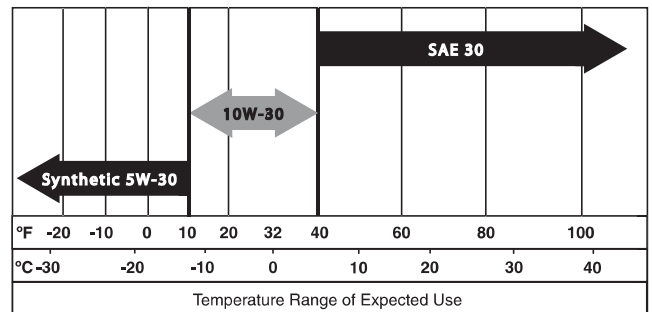

TO ADD ENGINE OIL TO THE CRANKCASE

1. Place the unit on a firm, level surface.
2. Remove the Left Side Service Cover.
3. Remove the oil fill cap located on the bottom of the engine crankcase.
4. Add the recommended engine oil slowly, stopping frequently to check the level. The full level is the base of the threads in the filler neck. **DO NOT OVERFILL!**
5. Replace the oil fill cap and tighten.
6. Always check the oil level before starting the generator engine.

⚠ CAUTION!

⚠ **DO NOT overfill the engine crankcase with oil. High oil pressure may result, causing premature engine wear and damage.**

Figure 9 - Oil Fill

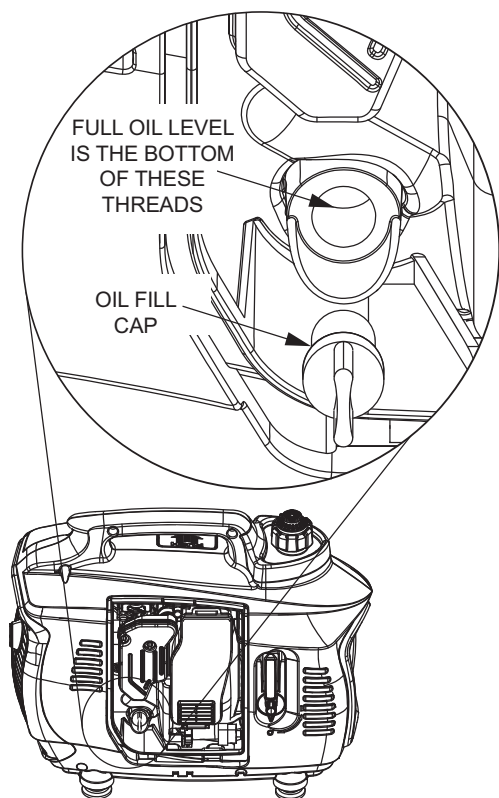

GENERATOR MAINTENANCE

Proper care will ensure maximum performance of your generator. Generator maintenance consists of keeping the unit clean and dry. Operate and store the unit in a clean dry environment where it will not be exposed to excessive dust, dirt, moisture or any corrosive vapors.

Cooling air slots in the generator must not become clogged with snow, leaves, or any other foreign material.

Check the cleanliness of the generator frequently and clean when dust, dirt, oil, moisture or other foreign substances are visible on its exterior surface.

NOTE:

Never insert any object or tool through the air cooling slots, even if the engine is not running.

NOTE:

DO NOT use a garden hose to clean the generator. Water can enter the engine fuel system and cause problems. In addition, if water enters the generator through cooling air slots, some water will be retained in voids and crevices of the rotor and stator winding insulation. Water and dirt buildup on the generator internal windings will eventually decrease the insulation resistance of these windings.

GENERATOR MAINTENANCE SCHEDULE

Follow the recommended service schedule; to order replacement parts call 1-888-436-3722.

	Each Use	Every 100 Hours	Every 6 Months	Each Year
Fuel Level	X			
Oil Level	X			
Check Air Filter	X			
*Change Engine Oil		X		
**Clean Air Filter		X		
Check Spark Plug			X	
Check Muffler			X	
Replace Spark Plug				X
Replace Fuel Filter				X

* Perform initial oil change after the first five (5) hours of operation
 ** Clean the air filter more often if operating in dusty or sandy conditions. Replace as necessary.

CLEANING THE GENERATOR

1. Use a damp cloth to wipe exterior surfaces clean.
2. A soft, bristle brush may be used to loosen caked on dirt, oil, etc.
3. A vacuum cleaner may be used to pick up loose dirt and debris.
4. Low pressure air (not to exceed 25 psi) may be used to blow away dirt. Inspect cooling air slots and openings on the generator. These openings must be kept clean and unobstructed.
5. Inspect the vent hoses on the left side of the generator. Make sure the hoses protrude through the slots below the door and that the ends are open and free of debris.

ENGINE MAINTENANCE

NOTE:

Only work on a generator that has cooled completely.

Inspect the oil level and air filter condition each time you are going to use the generator. To check the air filter and oil level the left side service cover must be removed; use a screwdriver to loosen the screw securing the cover and remove.

The air filter is located behind a cover for the air box (Figure 10). Push the tab on the bottom of the air box up wards to release the cover. To service the air cleaner:

1. Remove the air cleaner. Tap the element to shake loose any large particles.
2. Wash the element in soapy water. Squeeze the filter dry in clean cloth (DO NOT TWIST).
3. Soak the filter element in clean engine oil. Squeeze the excess oil from the filter, leaving a light coating.
4. Clean air cleaner housing and cover before re-installing the filter element.

Figure 10 - Air Filter

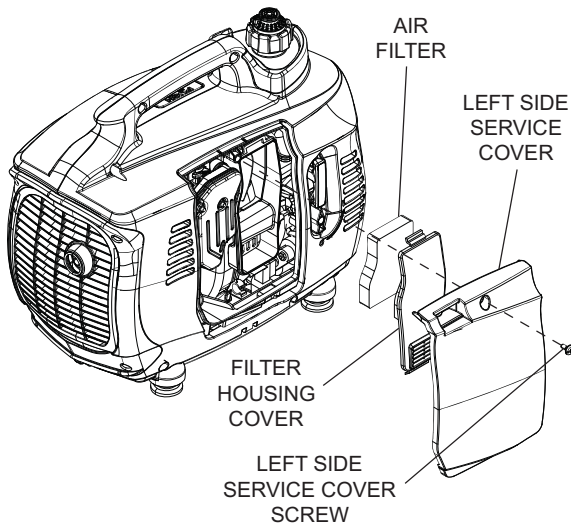

CHANGING THE ENGINE OIL

⚠ CAUTION!

- ⚠ **Hot oil may cause burns. Allow engine to cool entirely before draining oil. Avoid prolonged or repeated skin exposure with used oil. Thoroughly wash exposed areas with soap.**

Change the engine oil after the first five (5) hours of operation. Change the engine oil every 100 hours thereafter. To change the engine oil:

1. Run the generator briefly to warm the engine oil; this also loosens any engine deposits and makes the used oil flow easier.

⚠ CAUTION!

- ⚠ **Change the oil only when the fuel tank is low or nearly empty. Tipping the generator with a full fuel tank may cause fuel leakage.**
2. Place the generator over a drain pan and remove the drain plug. Tip the generator on its side to drain the used oil from the crankcase.

NOTE:

To make draining the oil easier, a 6" length of vinyl (PVC) hose with an inside diameter of 1.25" (32mm) may be placed over the drain lip.

3. Tip the generator upright once the oil has finished draining. Replace the engine oil with the proper grade called out in Section "ADDING ENGINE OIL", then replace the drain plug.

CHANGING THE FUEL FILTER

Locate the fuel filter, just below the engine intake housing (Figure 11). Make sure the Fuel Shutoff is in the "OFF" (O) position.

1. Remove the pinch clamps securing the fuel filter. Pull the hoses free.

⚠ WARNING!

- ⚠ **Wipe up any fuel spills immediately! Do not smoke or replace the fuel filter near sparks or open flame!**

2. Replace the used filter with a new one. Push the fuel hoses onto the barbed filter fittings until they are seated completely.
3. Replace the clamps, making sure they are seated on the fittings.

Figure 11 - Fuel Filter

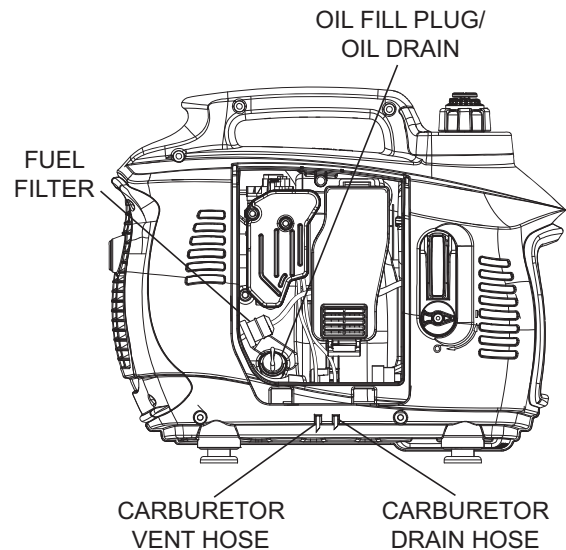

CHANGING THE SPARK PLUG

Replace the spark plug each year, regardless of how many hours the generator has been run. Use a NGK CR5H88 or Denso U16FSR-UB that has been gapped to .030" (.76mm). To replace the spark plug:

1. Remove the spark plug cover on the top right side of the generator, just below the handle (Figure 12).
2. Carefully pull the spark plug lead from the spark plug. Use a socket wrench to remove the spark plug.
3. Install the new spark plug into the cylinder head. Tighten the spark plug to 15 ft/lb.
4. Replace the spark plug lead, making sure it is fully seated.
5. Replace the spark plug cover.

Figure 12 - Replace Spark Plug

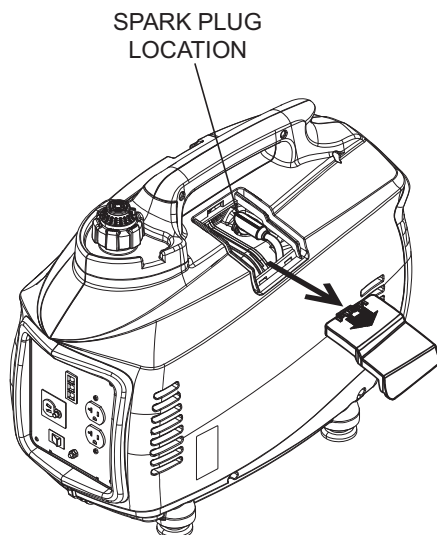
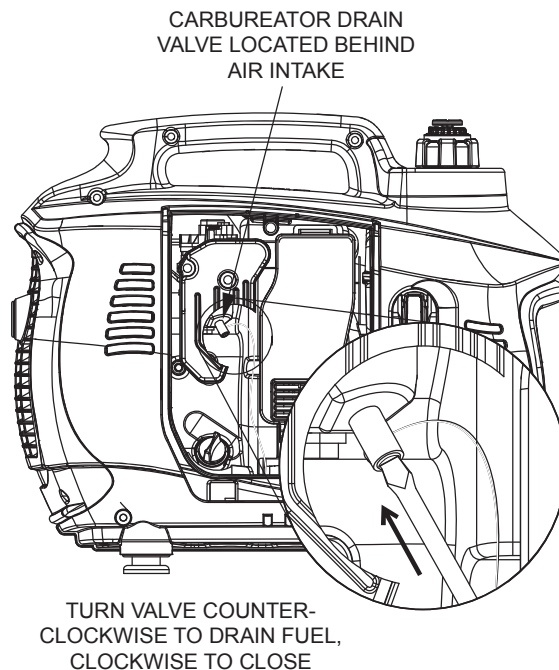

Figure 13 - Carburetor Drain Valve



TRANSPORTATION AND STORAGE

Transport or store the generator only if it has cooled completely. Make sure the fuel valve and the vent on the fuel cap are both in the OFF ("O") position.

It is important to prevent gum deposits from forming in essential fuel system parts such as the carburetor, fuel hose or tank during long-term storage. Also, experience indicates that alcohol-blended fuels (called gasohol, ethanol or methanol) can attract moisture, which leads to separation and formation of acids; these acids gas can damage the fuel system of an engine while in storage.

To avoid engine problems, the use of a commercial fuel stabilizer prior to storage is recommended. Follow the manufacturer's instructions when adding the fuel stabilizer.

If the generator is going to be stored for more than six (6) months, the generator should be prepared as follows:

1. Remove all gasoline from the fuel tank.
2. Start and run engine until engine stops from lack of fuel or open the valve on carburetor bowl (Figure 13), and allow gasoline to drain down tube into a receptacle. Discard appropriately. Be sure to close the valve once the gasoline has drained.

3. While engine is still warm, drain oil from crankcase. Refill with recommended grade.
4. Remove spark plugs and pour about 1/2 ounce (15 ml) of engine oil into the cylinders. Cover spark plug hole with rag. Pull the starting rope several times to coat the cylinder walls with engine oil.
5. Install and tighten the spark plug.
6. Clean the generator outer surfaces. Check that cooling air slots and openings on generator are open and unobstructed.
7. Store the unit in a clean, dry place.

Do not store gasoline from one season to another.

If possible, store the unit indoors and cover it to give protection from dust and dirt.

Troubleshooting

4.1 TROUBLESHOOTING GUIDE

PROBLEM	CAUSE	CORRECTIVE ACTION
Engine won't start.	<ol style="list-style-type: none"> 1. No fuel in tank. 2. Fuel valve turned off. 3. Defective spark plug. 4. Plugged fuel filter. 5. Defective or stuck engine stop switch. 	<ol style="list-style-type: none"> 1. Add fuel to tank. 2. Turn fuel valve on. 3. Replace spark plug. 4. Replace fuel filter. 5. Replace engine start switch.
Engine starts, then shuts down.	<ol style="list-style-type: none"> 1. Low fuel level. 2. Fuel tank vent closed. 3. Incorrect engine oil level. 4. Contaminated fuel. 5. Defective low oil level switch. 6. Defective ignition coil. 	<ol style="list-style-type: none"> 1. Add fuel to tank. 2. Open fuel tank vent. 3. Check engine oil level, add or drain as needed. 4. Replace fuel filter. 5. Replace Low Oil Level switch. 6. Replace ignition coil.
Engine starts, then runs rough.	<ol style="list-style-type: none"> 1. Choke is stuck or left on. 2. Dirty or clogged air filter. 3. Defective or dirty spark plug. 4. Dirty fuel filter. 5. Defective FlexPower switch. 	<ol style="list-style-type: none"> 1. Turn choke off. 2. Clean or replace the air filter element. 3. Replace spark plug. 4. Replace fuel filter. 5. Replace FlexPower switch.
No AC output.	<ol style="list-style-type: none"> 1. Generator is overloaded (OVERLOAD LED is on). 2. AC voltage is low (OVERLOAD LED is on). 3. Inverter module is overheated (OVERLOAD LED is on). 4. Short circuit in load (OVERLOAD LED is on). 5. Defective inverter assembly. 	<ol style="list-style-type: none"> 1. Shut down generator to reset module. Reduce loads and restart generator. 2. Verify vent is open and choke is OFF. 3. Verify service door is ON. Let cool for 15 minutes and restart generator. 4. Verify condition of any extension cords and all loads being powere. 5. Replace inverter assembly.
No DC output. **	<ol style="list-style-type: none"> 1. DC circuit breaker is open. 2. Defective DC circuit breaker. 3. Defective rectifier. 	<ol style="list-style-type: none"> 1. Reset DC circuit breaker. 2. Replace DC circuit breaker. 3. Replace rectifier.
Fuel leaks from drain hoses.	<ol style="list-style-type: none"> 1. Fuel system over primed (flooded). 2. Carburetor drain in bowl is not closed. 	<ol style="list-style-type: none"> 1. Turn vent in cap ON and let generator sit 15 minutes before restarting. 2. Turn valve clockwise to close.

* Engine speed increases and decreases — This is normal as the generator starts up and as loads vary.

** Verify FlexPower Switch is in the "O" OFF position.

FEDERAL EMISSION CONTROL WARRANTY STATEMENT YOUR WARRANTY RIGHTS AND OBLIGATIONS

The United States Environmental Protection Agency (EPA) and Generac Power Systems, Inc. (Generac) are pleased to explain the Emission Control System warranty on your new 2008 and later equipment. New equipment that use small spark-ignited engines must be designed, built, and equipped to meet stringent anti-smog standards for the federal government. Generac will warrant the emission control system on your generator for the period of time listed below provided there has been no abuse, neglect, unapproved modification or improper maintenance of your equipment.

Your emission control system may include parts such as the: carburetor, ignition system, fuel system, catalytic converter, and other associated emission-related components (if equipped).

MANUFACTURER'S WARRANTY COVERAGE:

This emission control system is warranted for two years. If, during such warranty period, any emission-related part on your equipment is found to be defective in materials or workmanship, repairs or replacement will be performed by a Generac Authorized Warranty Service Dealer.

OWNER'S WARRANTY RESPONSIBILITIES:

As the generator owner, you are responsible for the completion of all required maintenance as listed in your factory supplied Owner's Manual. For warranty purposes, Generac recommends that you retain all receipts covering maintenance on your generator, but Generac cannot deny warranty solely due to the lack of receipts.

As the generator owner, you should be aware that Generac may deny any and/or all warranty coverage or responsibility if your generator, or a part/component thereof, has failed due to abuse, neglect, improper maintenance or unapproved modifications, or the use of counterfeit and/or "grey market" parts not made, supplied or approved by Generac.

You are responsible for contacting a Generac Authorized Warranty Dealer as soon as a problem occurs. The warranty repairs should be completed in a reasonable amount of time, not to exceed 30 days.

Warranty service can be arranged by contacting either your selling dealer or a Generac Authorized Warranty Service Dealer. To locate the Generac Authorized Warranty Service Dealer nearest you, call our toll free number:

1-800-333-1322

IMPORTANT NOTE: This warranty statement explains your rights and obligations under the Emission Control System Warranty (ECS Warranty), which is provided to you by Generac pursuant to federal law. See also the "Generac Limited Warranties for Generac Power Systems, Inc.," which is enclosed herewith on a separate sheet, also provided to you by Generac. Note that this warranty shall not apply to any incidental, consequential or indirect damages caused by defects in materials or workmanship or any delay in repair or replacement of the defective part(s). This warranty is in place of all other warranties, expressed or implied. Specifically, Generac makes no other warranties as to the merchantability or fitness for a particular purpose. Some states do not allow limitations on how long an implied warranty lasts, so the above limitation may not apply to you.

The ECS Warranty applies only to the emission control system of your new equipment. If there is any conflict in terms between the ECS Warranty and the Generac Warranty, the Generac Warranty shall apply. Both the ECS Warranty and the Generac Warranty describe important rights and obligations with respect to your new engine.

Warranty service can be performed only by a Generac Authorized Warranty Service Facility. When requesting warranty service, evidence must be presented showing the date of the sale to the original purchaser/owner.

If you have any questions regarding your warranty rights and responsibilities, you should contact Generac at the following address:

**ATTENTION WARRANTY DEPARTMENT
GENERAC POWER SYSTEMS, INC.
P.O. BOX 297 • WHITEWATER, WI 53190**

Part 1

EMISSION CONTROL SYSTEM WARRANTY

Emission Control System Warranty (ECS warranty) for equipment using small spark-ignited engines:

- (a) **Applicability:** This warranty shall apply to equipment that uses small off-road engines. The ECS Warranty period shall begin on the date the new equipment is purchased by/delivered to its original, end-use purchaser/owner and shall continue for 24 consecutive months thereafter.
- (b) **General Emissions Warranty Coverage:** Generac warrants to the original, end-use purchaser/owner of the new engine or equipment and to each subsequent purchaser/owner that the ECS when installed was:
 - (1) Designed, built and equipped so as to conform with all applicable regulations; and
 - (2) Free from defects in materials and workmanship which cause the failure of a warranted part at any time during the ECS Warranty Period.
- (c) The warranty on emissions-related parts will be interpreted as follows:
 - (1) Any warranted part that is not scheduled for replacement as required maintenance in the Owner's Manual shall be warranted for the ECS Warranty Period. If any such part fails during the ECS Warranty Period, it shall be repaired or replaced by Generac according to Subsection (4) below. Any such part repaired or replaced under the ECS Warranty shall be warranted for the remainder of the ECS Warranty Period.
 - (2) Any warranted part that is scheduled only for regular inspection as specified in the Owner's Manual shall be warranted for the ECS Warranty Period. A statement in the Owner's Manual to the effect of "repair or replace as necessary" shall not reduce the ECS Warranty Period. Any such part repaired or replaced under the ECS Warranty shall be warranted for the remainder of the ECS Warranty Period.
 - (3) Any warranted part that is scheduled for replacement as required maintenance in the Owner's Manual shall be warranted for the period of time prior to first scheduled replacement point for that part. If the part fails prior to the first scheduled replacement, the part shall be repaired or replaced by Generac according to Subsection (4) below. Any such emissions-related part repaired or replaced under the ECS warranty shall be warranted for the remainder of the period prior to the first scheduled replacement point for that part.
 - (4) Repair or replacement of any warranted, emissions-related part under this ECS Warranty shall be performed at no charge to the owner at a Generac Authorized Warranty Service Facility.
 - (5) Notwithstanding the provisions of subsection (4) above, warranty services or repairs must be provided at Generac Authorized Service Facilities.
 - (6) When the engine is inspected by a Generac Authorized Warranty Service Facility, the purchaser/owner shall not be held responsible for diagnostic costs if the repair is deemed warrantable.
 - (7) Throughout the ECS Warranty Period, Generac shall maintain a supply of warranted emission-related parts sufficient to meet the expected demand for such parts.
 - (8) Any Generac authorized and approved emission-related replacement parts may be used in the performance of any ECS warranty maintenance or repairs and will be provided without charge to the purchaser/owner. Such use shall not reduce Generac ECS Warranty obligations.
 - (9) Unapproved, add-on, modified, counterfeit and/or "grey market" parts may not be used to modify or repair a Generac engine. Such use voids this ECS Warranty and shall be sufficient grounds for disallowing an ECS Warranty claim. Generac shall not be held liable hereunder for failures of any warranted parts of Generac equipment caused by the use of such an unapproved, add-on, modified, counterfeit and/or "grey market" part.

EMISSION RELATED PARTS MAY INCLUDE THE FOLLOWING (IF EQUIPPED):

- | | |
|--|--|
| <ol style="list-style-type: none"> 1) FUEL METERING SYSTEM <ol style="list-style-type: none"> A. CARBURETOR AND INTERNAL PARTS B. PRESSURE REGULATOR 2) AIR INDUCTION SYSTEM <ol style="list-style-type: none"> A. INTAKE MANIFOLD B. AIR FILTER 3) IGNITION SYSTEM <ol style="list-style-type: none"> A. SPARK PLUGS B. IGNITION COILS / MODULE | <ol style="list-style-type: none"> 4) AIR INJECTION SYSTEM <ol style="list-style-type: none"> A. PULSE AIR VALVE 5) EXHAUST SYSTEM <ol style="list-style-type: none"> A. CATALYST B. THERMAL REACTOR C. EXHAUST MANIFOLD |
|--|--|

Part 2

Warranty

GENERAC POWER SYSTEMS "TWO YEAR" LIMITED WARRANTY FOR IX SERIES PORTABLE GENERATORS

For a period of two years from the date of original sale, Generac Power Systems, Inc. (Generac) warrants its iX Series generators will be free from defects in materials and workmanship for the items and period set forth below. Generac will, at its option, repair or replace any part which, upon examination, inspection and testing by Generac or a Generac Authorized Warranty Service Dealer, is found to be defective. Any equipment that the purchaser/owner claims to be defective must be returned to and examined by the nearest Generac Authorized Warranty Service Dealer. All transportation costs under the warranty, including return to the factory, are to be borne and prepaid by the purchaser/owner. This warranty applies only to Generac iX Series portable generators and is not transferable from original purchaser. Save your proof-of-purchase receipt. If you do not provide proof of the initial purchase date, the manufacturer's shipping date of the product will be used to determine the warranty period.

**** This warranty only applies to units sold for use in the U.S.A. and Canada.****

WARRANTY SCHEDULE

Consumer applications are warranted for two (2) years. Commercial and Rental applications are warranted for six (6) months.

CONSUMER APPLICATION

YEAR ONE - Limited Comprehensive coverage on Labor and Part(s) listed (proof of purchase and maintenance is required):

- Engine- All Components
- Alternator- All Components

YEAR TWO - Limited Comprehensive coverage on Part(s) listed (proof of purchase and maintenance is required):

- Engine- All Components
- Alternator- All Components

COMMERCIAL/RENTAL APPLICATION

FIRST SIX MONTHS – Limited Comprehensive coverage on Labor and Part(s) listed (proof of purchase and maintenance is required):

- Engine- All Components
- Alternator- All Components

NOTE: For the purpose of this warranty "consumer use" means personal residential household or recreational use by original purchaser. This warranty does not apply to units used for Prime Power in place of utility where utility power service is present or where utility power service does not normally exist. Once a generator has experienced commercial or rental use, it shall thereafter be considered a non-consumer use generator for the purpose of this warranty.

All warranty expense allowances are subject to the conditions defined in Generac's Service Policy Manual.

THIS WARRANTY SHALL NOT APPLY TO THE FOLLOWING:

- Generac portable generators that utilize non-Generac replacement parts.
- Costs of normal maintenance and adjustments.
- Failures caused by any contaminated fuels, oils or lack of proper oil levels.
- Repairs or diagnostics performed by individuals other than Guardian/Generac authorized dealers not authorized in writing by Generac Power Systems.
- Failures due, but not limited, to normal wear and tear, accident, misuse, abuse, negligence or improper use. As with all mechanical devices, the Generac engines need periodic part(s) service and replacement to perform as designed. This warranty will not cover repair when normal use has exhausted the life of a part(s) or engine.
- Failures caused by any act of God and other force majeure events beyond the manufacturer's control.
- Damage related to rodent and/or insect infestation.
- Products that are modified or altered in a manner not authorized by Generac in writing.
- Any incidental, consequential or indirect damages caused by defects in materials or workmanship, or any delay in repair or replacement of the defective part(s).
- Failure due to misapplication.
- Telephone, cellular phone, facsimile, internet access or other communication expenses.
- Living or travel expenses of person(s) performing service, except as specifically included within the terms of a specific unit warranty period.
- Expenses related to "customer instruction" or troubleshooting where no manufacturing defect is found.
- Rental equipment used while warranty repairs are being performed.
- Overnight freight or special shipping costs for replacement part(s).
- Overtime, holiday or emergency labor.
- Starting batteries, fuses, light bulbs and engine fluids.

THIS WARRANTY IS IN PLACE OF ALL OTHER WARRANTIES, EXPRESSED OR IMPLIED, SPECIFICALLY, GENERAC POWER SYSTEMS MAKES NO OTHER WARRANTIES AS TO THE MERCHANTABILITY OR FITNESS FOR A PARTICULAR PURPOSE. Any implied warranties which are allowed by law, shall be limited in duration to the terms of the express warranty provided herein. Some states do not allow limitations on how long an implied warranty lasts, so the above limitation may not apply to purchaser/owner.

GENERAC POWER SYSTEMS ONLY LIABILITY SHALL BE THE REPAIR OR REPLACEMENT OF PART(S) AS STATED ABOVE. IN NO EVENT SHALL GENERAC POWER SYSTEMS BE LIABLE FOR ANY INCIDENTAL, OR CONSEQUENTIAL DAMAGES, EVEN IF SUCH DAMAGES ARE A DIRECT RESULT OF GENERAC POWER SYSTEMS, INC. NEGLIGENCE. Some states do not allow the exclusion or limitation of incidental or consequential damages, so the above limitations may not apply to purchaser/owner. Purchaser/owner agrees to make no claims against Generac Power Systems, Inc. based on negligence. This warranty gives purchaser/owner specific legal rights. Purchaser/owner also may have other rights that vary from state to state.

GENERAC POWER SYSTEMS, INC.

P.O. BOX 8 • Waukesha, WI 53187

Ph: (888) GENERAC (436-3722) • Fax: (262) 544-4851

To locate the nearest Authorized Dealer visit our website www.generac.com